

Cooker with gas oven and gas grill

Instructions for installation and use

K 34 G/G

K 340 G/G

K 341 G/G

K 342 G/G

K 344 G/G

 **INDESIT**



GB **Cooker with gas oven and gas grill**
Instructions for installation and use

Important safety warnings

To maintain the **EFFICIENCY** and **SAFETY** of this appliance, we recommend:

- call only the Service Centers authorized by the manufacturer
- always use original Spare Parts

- 1 This appliance is intended for nonprofessional use within the home.
- 2 These instructions are only for those countries whose symbols appear in the booklet and on the serial no. plate of the appliance.
- 3 **This owner's manual is for a class 1 appliance (insulated) or class 2, subclass 1 appliances (installed between two cabinets).**
- 4 Before using your appliance, read the instructions in this owner's manual carefully since it provides all the information you need to ensure safe installation, use and maintenance. Always keep this owner's manual close to hand since you may need to refer to it in the future.
- 5 When you have removed the packing, check that the appliance is not damaged. If you have any doubts, do not use the appliance and contact your nearest Ariston Service Centre. Never leave the packing components (plastic bags, polystyrene foam, nails, etc.) within the reach of children since they are a source of potential danger.
- 6 The appliance must be installed only by a qualified technician in compliance with the instructions provided. The manufacturer declines all liability for improper installation, which may result in personal injury and damage to property.
- 7 The electrical safety of this appliance can only be guaranteed if it is correctly and efficiently earthed, in compliance with regulations on electrical safety. Always ensure that the earthing is efficient. If you have any doubts, contact a qualified technician to check the system. The manufacturer declines all liability for damage resulting from a system which has not been earthed.
- 8 Before plugging the appliance into the mains, check that the specifications indicated on the date plate (on the appliance and/or packaging) correspond with those of the electrical and gas systems in your home.
- 9 Check that the electrical capacity of the system and sockets will support the maximum power of the appliance, as indicated on the data plate. If you have any doubts, contact a qualified technician.
- 10 An omnipolar switch with a contact opening of at least 3 mm or more is required for installation.
- 11 If the socket and appliance plug are not compatible, have the socket replaced with a suitable model by a qualified technician, who should also check that the cross-section of the socket cable is sufficient for the power absorbed by the appliance. The use of adaptors, multiple sockets and/or extensions, is not recommended. If their use cannot be avoided, remember to use only single or multiple adapters and extensions which comply with current safety regulations. In these cases, never exceed the maximum current capacity indicated on the individual adaptor or extension and the maximum power indicated on the multiple adapter.
- 12 Do not leave the appliance plugged in if it is not in use. Switch off the main switch and gas supply when you are not using the appliance.
- 13 The openings and slots used for ventilation and heat dispersion must never be covered.
- 14 The user must not replace the supply cable of this appliance. Always contact an after-sales service centre which has been authorised by the manufacturer if the cable has been damaged or needs replacement.
- 15 This appliance must be used for the purpose for which it was expressly designed. Any other use (e.g. heating rooms) is considered to be improper and consequently dangerous. The manufacturer declines all liability for damage resulting from improper and irresponsible use.
- 16 A number of fundamental rules must be followed when using electrical appliances. The following are of particular importance:
 - Do not touch the appliance when your hands or feet are wet.
 - Do not use the appliance barefooted.
 - Do not use extensions, but if they are necessary, caution must be exercised.
 - Never pull the power supply cable or the appliance to unplug the appliance plug from the mains.
 - Never leave the appliance exposed to atmospheric agents (rain, sun etc.)
 - Do not allow children or persons who are not familiar with the appliance to use it, without supervision.
- 17 Always unplug the appliance from the mains or switch off the main switch before cleaning or carrying out maintenance.
- 18 If you are no longer using an appliance of this type, remember to make it unserviceable by unplugging the appliance from the mains and cutting the supply cable. Also make all potentially dangerous parts of the appliance safe, above all for children who could play with the appliance.
- 19 To avoid accidental spillage do not use cookware with uneven or deformed bottoms on the burners. Turn the handles of pots and pans inwards to avoid knocking them over accidentally.
- 20 Some parts of the appliance remain heated for a long time after use. Make sure not to touch them.
- 21 Never use flammable liquids such as alcohol or gasoline, etc. near the appliance when it is in use.
- 22 When using small electric appliances near the hob, keep the supply cord away from the hot parts.
- 23 Make sure the knobs are in the "•"/"o" position when the appliance is not in use.
- 24 When the appliance is in use, the heating elements and some parts of the oven door become extremely hot. Make sure you don't touch them and keep children well away.
- 25 **Gas appliances require regular air exchange to ensure trouble-free performance. When installing the cooker, follow the instructions provided in the paragraph on "Positioning" the appliance.**
- 26 The glass top (only on certain models) can shatter if it is overheated. Therefore, all of the burners or hot plates must be turned off before the top is closed.
- 27 If the cooker is placed on a pedestal, take the necessary precautions to prevent the same from sliding off the pedestal itself.

Installation

All instruction on the following pages must be carried out by a competent person (corgi registered) in compliance with gas safety (installation and use) regulation 1984.

Important: disconnect the cooker from the electricity and gas supply when any adjustment, etc.

Positioning

Important: this unit may be installed and used only in permanently ventilated rooms according to the British Standards Codes Of Practice: B.S. 6172/B.S. 5440, Par. 2 and B.S. 6891 Current Editions. The following requirements must be observed:

- The cooker should not be installed in a bed sitting room with a volume of less than 20m^3 . If it is installed in a room of volume less than 5m^3 an air vent of effective area of 110cm^2 is required, if it is installed in a room of volume between 5m^3 and 10m^3 a supplementary airvent area of 50cm^2 is required, if the volume exceeds 11m^3 no airvent is required. However, if the room has a door or a window which opens directly to the outside no air vent is required even when the volume is between 5m^3 and 11m^3 .
- During prolonged use of the appliance you may consider it necessary to open a window to the outside to improve ventilation.
- If there are other fuel burning appliances in the same room, B.S.5440 Part 2 Current Edition, should, be consulted to determine the requisite air vent requirements.

Levelling your appliance (only on a few models)

Your cooker is supplied with feet for levelling the appliance. If necessary, these feet can be screwed into the housings in the corners of the cooker base.

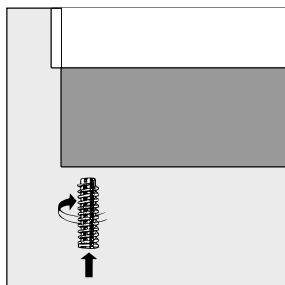

Mounting the legs (only on a few models)

Press-fit legs are supplied which fit under the base of your cooker.

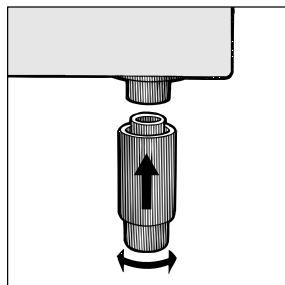

Installation of the cooker

The appliance can be installed next to furniture units which are no taller than the top of the cooker hob. The wall in direct contact with the back panel of the cooker must be made of non-flammable material. During operation the

back panel of the cooker could reach a temperature of 50°C above room temperature. For proper installation of the cooker, the following precautions must be taken:

- The appliance can be placed in a kitchen, dining room or bedsit, but not in a bathroom.
- All furniture around the appliance must be placed at least 200 mm from the top of the cooker, should the surface of the appliance be higher than the worktop of this furniture. Curtains should not be placed behind the cooker or less than 200 mm away from the sides of the appliance.
- Any hoods must be installed according to the requirements in the installation manual for the hoods themselves.
- If the cooker is installed beneath a wall cabinet, the latter must be situated at a minimum of 420 mm above the hob. The minimum distance between the worktop and kitchen units made of combustible material is 700 mm (Fig. A).
- The wall in direct contact with the back panel of the cooker must be made of non-flammable materials.
- The cooker is fitted with a safety chain that must be attached to a hook, secured to the wall behind the appliance.

Note: some models can have their gas connection inverted. It is important to make sure the safety chain is always situated on the side which corresponds to the hose holder (Fig. B).

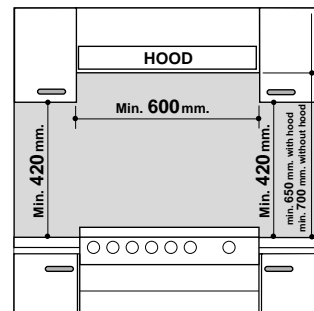

Fig. A

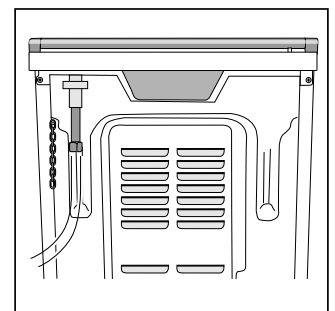
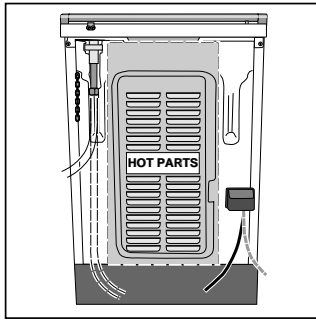

Fig. B

Gas connection

The cooker should be connected to the gas-supply by a corgi registered installer. During installation of this product it is essential to fit an approved gas tap to isolate the supply from the appliance for the convenience of any subsequent removal or servicing. Connection of the appliance to the gas mains or liquid gas must be carried out according to the prescribed regulation in force, and only after it is ascertained that it is adaptable to the type of gas to be used. If not, follow the instructions indicated in the paragraph headed "Adaptation to different gas types". On some models the gas supply can be connected on the left or on the right, as necessary; to change the connection, reverse the position of the hose holder with that of the cap and replace the gasket (supplied with the appliance). In the case of connection to liquid gas, by tank, use pressure regulators that conform to the regulation in force. The gas supply must be connected to the left of the appliance. Be sure that the hose does not pass through the rear of the cooker touching hot parts.



Important: make sure the supply pressure conforms with the values shown in the table entitled "Characteristics of the burners and nozzles". **When the cooker is installed between cabinets (recessed), the gas connection must be effected by an approved flexible hose with bayonet fitting (BS 669 Current Edition). The gas inlet for the cookers is a threaded G 1/2 gas female fitting.**

Connecting the gas supply

To make the connection, a flexible hose should be used corresponding to the current gas regulations which are:

- the hose must never be at any point in its length in contact with the "hot" parts of the cooker;
- the hose must never be longer than 1,5 metre;
- the hose must not be subject to any tension or torsional stress and it must not have any excessively narrow curves or bottlenecks;
- the hose must be easy to inspect along its entire length to check its condition;
- the hose must always be in good condition, never attempt to repair.

Important: the installation must comply with gas safety (installation and use) regulations 1984. In all cases for the above, by law, a qualified, corgi approved engineer must be called for installation.

Electrical connection

Power supply voltage and frequency: 230-240V a.c. 50/60 Hz.

Note: the supply cable must be positioned so that it never reaches at any point a temperature 50°C higher than the room temperature. The cable must be routed away from the rear vents. Should you require it, you may use a longer cable, however, you must ensure that the cable supplied with the appliance is replaced by one of the same specifications in accordance with current standards and legislation.

Your appliance is supplied with a 13 amp fused plug that can be plugged into a 13 amp socket for immediate use. Before using the appliance please read the instructions below.

WARNING - THIS APPLIANCE MUST BE EARTHED. THE FOLLOWING OPERATIONS SHOULD BE CARRIED OUT BY A QUALIFIED ELECTRICIAN.

Replacing the fuse:

When replacing a faulty fuse, a 13 amp ASTA approved fuse to BS 1362 should always be used, and the fuse cover refitted. If the fuse cover is lost, the plug must not be used until a replacement is obtained.

Replacement fuse covers:

If a replacement fuse cover is fitted, it must be of the correct colour as indicated by the coloured marking or the colour that is embossed in words on the base of the plug. Replacements can be obtained directly from your nearest

Service Depot.

Removing the plug:

If your appliance has a non-rewireable moulded plug and you should wish to remove it to add a cable extension or to re-route the mains cable through partitions, units etc., please ensure that either:

- the plug is replaced by a fused 13 amp re-wireable plug bearing the BSI mark of approval.
- or:
- the mains cable is wired directly into a 13 amp cable outlet, controlled by a switch, (in compliance with BS 5733) which is accessible without moving the appliance.

Please note: for appliances with a rating greater than 13 amp (eg: electric hob, double ovens and freestanding electric cookers etc.) the mains cable must be wired into a cooker output point with a rating of 45 amp. In this case the cable is not supplied.

Disposing of the plug:

Ensure that before disposing of the plug itself, you make the pins unusable so that it cannot be accidentally inserted into a socket. Instructions for connecting cable to an alternative plug:

Important: the wires in the mains lead are coloured in accordance with the following code:

Green & Yellow	- Earth
Blue	- Neutral
Brown	- Live

If the colours of the wires in the mains lead do not correspond with the coloured markings identifying the terminals in your plug, proceed as follows:

Connect Green & Yellow wire to terminal marked "E" or \perp or coloured Green or Green & Yellow.

Connect Brown wire to terminal marked "L" or coloured Red.

Connect Blue wire to terminal marked "N" or coloured Black.

If a 13 amp plug (BS 1363) is used it must be fitted with a 13 amp fuse. A 15 amp plug must be protected by a 15 amp fuse, either in the plug or adaptor or at the distribution board. If you are in any doubt about the electrical supply to your machine, consult a qualified electrician before use.

How to connect an alternative plug:

The wires in this mains lead are coloured in accordance with the following code:

BLUE	"NEUTRAL" ("N")
BROWN	"LIVE" ("L")
GREEN AND YELLOW	"EARTH" ("E")

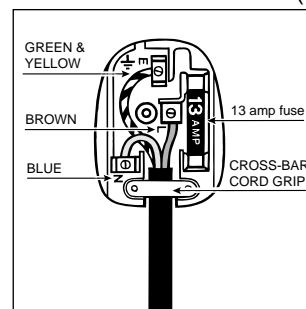

Disposing of the appliance

When disposing of the appliance please remove the plug by cutting the mains cable as close as possible to the plug body and dispose of it as described above.

Adapting the cooker to different types of gas

In order to adapt the cooker to a different type of gas with respect to the gas for which it was produced (indicated on the label attached to the lid), follow these steps:

a) replace the hose holder mounted on the appliance with that supplied in the bag of “cooker accessories”.

Important: the hose holder for liquid gas is marked 8, the hose holder for methane gas is marked 13. Always fit the sealing gasket.

b) Replacing the burner nozzles on the hob:

- remove the grids and slide the burners from their housings;
- unscrew the nozzles using a 7 mm socket spanner, and replace them with nozzles for the new type of gas (see table 1 “Burner and nozzle characteristics”).
- replace all the components by repeating the steps in reverse order.

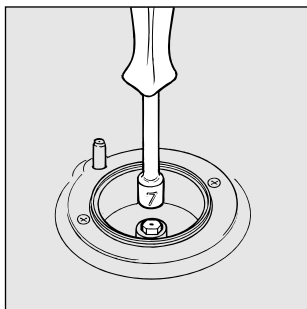

c) Minimum regulation of the hob burners:

- turn the tap to minimum;
- remove the knob and adjust the regulation screw, which is positioned in or next to the tap pin, until the flame is small but steady.

N.B.: in the case of liquid gas, the regulation screw must be screwed in to the bottom.

- check that the flame does not turn off when you turn the tap quickly from high to low.

d) Regulating the primary air of the burners:

The primary air of the burners requires no regulation.

Adapting the gas oven to different types of gas

a) Replacing the oven burner nozzle:

- remove the warming drawer;
- remove the sliding protection “A” (see Fig. C);
- remove the screw and then the oven burner “V” (see Fig. D). Remove the oven door to facilitate this operation.
- unscrew the oven burner nozzle using the special socket spanner for the nozzles (see Fig. E), or better still a 7 mm socket spanner, and replace it with a nozzle suited to the new type of gas (see table 1).

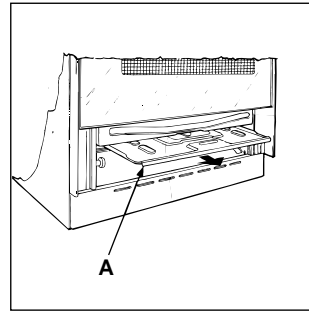

Fig. C

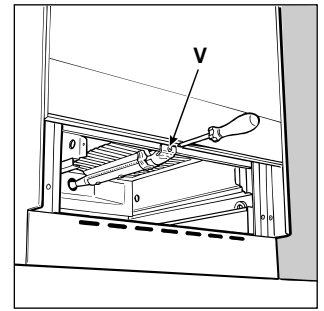

Fig. D

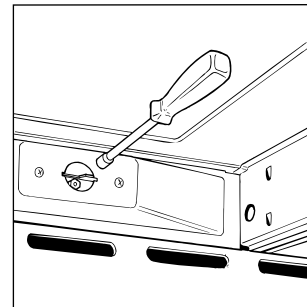
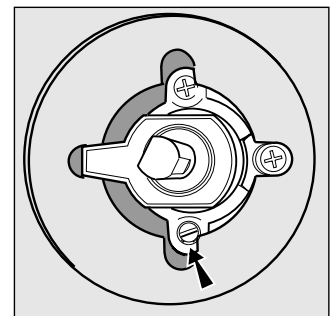
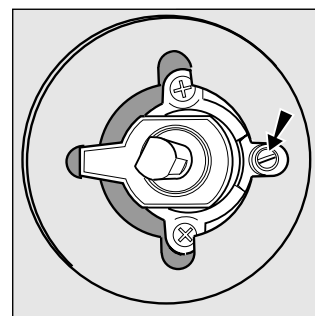

Fig. E

b) Minimum regulation of the gas oven burner with thermostat (see fig.):

- light the burner as described in the paragraph “the oven knob” of the instruction booklet.
- turn the knob to **Max** for about 10 minutes and then turn the knob to the **Min** setting;
- remove the knob;
- regulate the screw positioned outside the thermostat pin until the flame is small but steady.

N.B.: in the case of liquid gas, the regulation screw must be screwed in to the bottom.



- check that the burner does not turn off **when you turn the knob from Max to Min** and when you open and close the oven door quickly.

Adapting the gas grill to different types of gas

Replacing the nozzle of the grill burner:

- remove the screw and then slide out the grill burner “V” (see Fig. F);
- unscrew the grill burner nozzle using the special socket spanner for the nozzles (see Fig. G) or better still a 7 mm socket spanner; replace the nozzle with a nozzle for the new type of gas (see table 1).

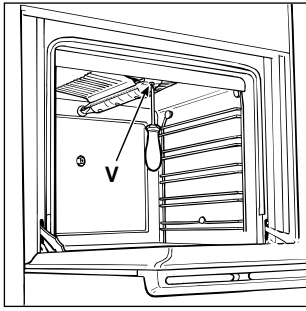

Fig. F

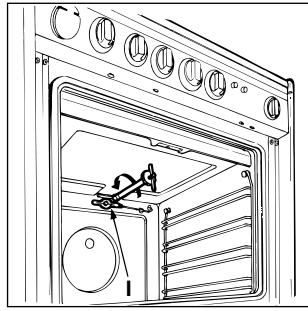
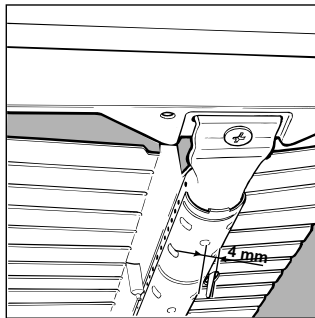

Fig. G

Important: when mounting the grill burner check that there is a space of at least 4 mm between the security thermocouple (if installed) and the burner.



Pay particular attention to the plug wires and thermocouple tubes.

Important

On completion of the operation, replace the old rating sticker with one indicating the new type of gas used. This sticker is available from our Service Centres.

Note

Should the pressure of the gas used be different (or vary) from the recommended pressure, it is necessary to fit a suitable pressure regulator onto the inlet pipe in compliance with current National Regulations relative to “regulators for channelled gas”.

Burner and nozzle characteristics

Table 1

Burner	Diameter (mm)	Thermal Power kW (p.c.s.*)		Liquid Gas				Natural Gas	
		Nominal	Reduced	By-Pass	Nozzle	Flow*		Nozzle	Flow*
				1/100	1/100	g/h			
				(mm)	(mm)	***	**	(mm)	l/h
Fast (Large)(R)	100	3.00	0.7	41	86	218	214	116	286
Semi Fast (Medium)(S)	75	1.90	0.4	30	70	138	136	106	181
Auxiliary (Small)(A)	55	1.00	0.4	30	50	73	71	79	95
Oven	-	3.10	1.0	46	85	225	221	132	295
Grill	-	2.50	-	-	80	182	179	122	227
Supply Pressures	Nominal (mbar)				28-30		37	20	
	Minimum (mbar)				20		25	17	
	Maximum (mbar)				35		45	25	

- * At 15°C and 1013 mbar- dry gas
- ** Propane P.C.S. = 50,37 MJ/Kg
- *** Butane P.C.S. = 49,47 MJ/Kg
- Natural P.C.S. = 37,78 MJ/m³

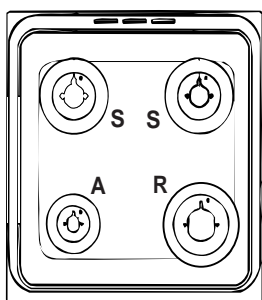

- K 34 G/G**
- K 340 G/G**
- K 341 G/G**
- K 342 G/G**
- K 344 G/G**

Technical characteristics

Inner dimensions of the oven:

Width: 39 cm
 Depth: 44 cm
 Height: 34 cm

Inner Volume of the Oven:

58 lt

Inner Dimensions of the Food Warmer:

Width: 42 cm
 Depth: 44 cm
 Height: 17 cm

Voltage and Frequency of Power Supply:

see data plate

Burners:

adaptable for use with all the types of gas indicated on the data plate situated inside the flap or, once the dishwarmer drawer has been opened, on the inside wall of the left-hand side panel.

This appliance conforms with the following European Economic Community directives:

- 73/23/EEC of 19/02/73 (Low Voltage) and subsequent modifications;
- 89/336/EEC of 03/05/89 (Electromagnetic Compatibility) and subsequent modifications;
- 90/396/EEC of 29/06/90 (Gas) and subsequent modifications;
- 93/68/EEC of 22/07/93 and subsequent modifications.

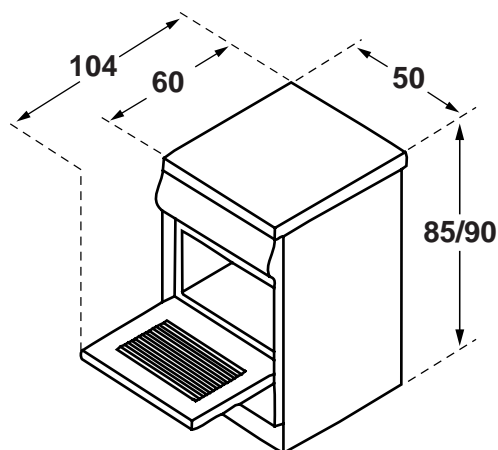

Mains frequency and voltage of the electric section and characteristics of the gas section

Model	Gas section		Electric section
	Class	Rated power kW (1)	Voltage
K 34 G/G	II2H3+	10.9 (793 g/h - G30) (778 g/h - G31)	230-240V~ 50/60Hz
K 340 G/G K 341 G/G K 342 G/G K 344 G/G	II2H3+	10.9 (793 g/h - G30) (778 g/h - G31)	

(1) The values in g/h refer to the capacities with liquid gas (Butane, Propane).

The cooker with gas oven

- A Tray for Catching Overflows
- B Gas Burner
- C Flame Failure Device for Cooktop Burners (only a few models)
- D Top Grate
- E Control Panel
- F Adjustable Feet or Legs
- G Dripping Pan or Baking Sheet
- H Electronic Lighting Device (only a few models)
- K Oven Rack
- L Electronic Lighting for Hob Burners (only on certain models)
- M Oven and Grill Control Knob
- N Control Knobs for Gas Burners on Hob
- O Button for Oven Light (only a few models)
- P Timer Knob (only a few models)

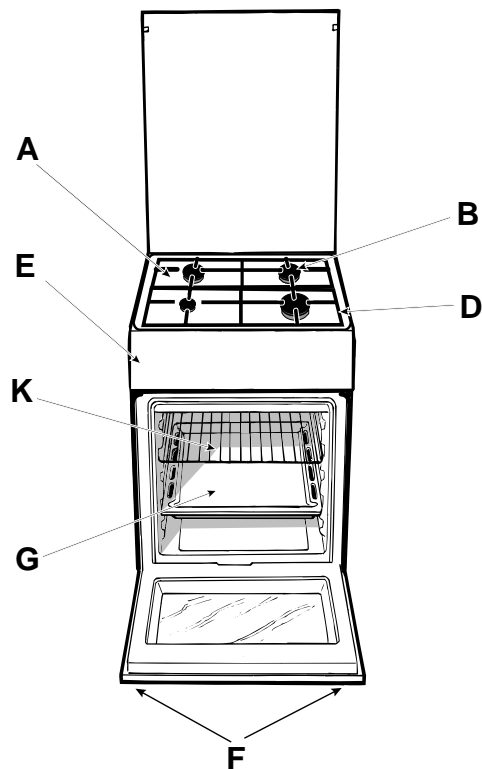
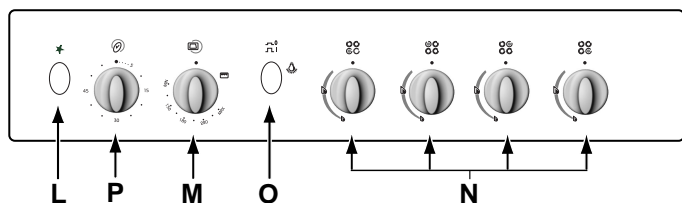
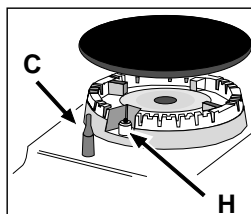

The different functions and uses of the oven

The various functions included in the cooker are selected by operating the control devices located on the cooker control panel.

Control Knobs for the Gas Burners on the Hob (N)

The position of the gas burner controlled by each one of the knobs is shown by a symbol of a solid ring: ●. To light one of the burners, hold a lighted match or lighter near the burner. Press down and turn the corresponding knob in the counter-clockwise direction to the **maximum** setting. Each burner can be operated at its maximum, minimum or intermediate power. Shown on the knob are the different symbols for off (the knob is on this setting when the symbol lines up with the reference mark on the control panel), for **maximum** and **minimum**. To obtain these settings, turn the knob counter-clockwise with respect to the off position. To turn off the burner, turn the knob clockwise until it stops (corresponding again with the ● symbol).

Electronic Ignition for the Gas Hob

Some of the models are provided with instant electronic lighting of the hob gas burners; these models are identified by the presence of a lighting device (see detail H). This device operates when a slight pressure is applied to the "L" button marked with

★ symbol. To light a specific burner just press the button labelled "L" while pushing the corresponding knob all the way in and turning it counter-clockwise until it lights. **For immediate lighting, first press the button and then turn the knob.**

Important: Should the burner flames accidentally go out, turn off the control knob and wait at least 1 minute before trying to relight.

Models with Hob Gas Burner Safety Devices to Prevent Leaks (only on certain models)

These models can be identified by the presence of the device itself (see detail C).

Important: Since the hob burners are equipped with a safety device, you must hold the control knob in for about 6 seconds after the burner has been lighted to allow the gas to pass until the safety thermocouple has heated.

Gas Cut Off (only on certain models)

This cooker has a safety cut out feature which switches off the burners when you close the cover. This device is provided as a safety feature in case the cover is lowered with the burners on.

Attention: after the re-opening of the glass cover in order to restore the gas cut-off, it is necessary to press manually the push-button situated in the posterior part to right of

the hob of the cooker (as indicated in figure).

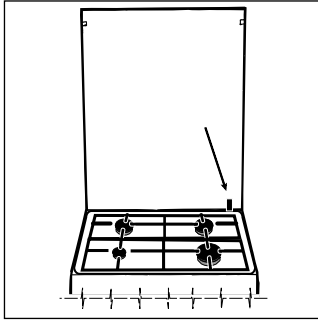

Always turn off the gas and allow the burners to cool before closing the cover. Failure to follow these instructions may cause the glass cover to shatter. Keep the cover open when using the oven.

Attention: before using the oven and grill for the first time, turn the oven on for approximately one half hour. Make sure that the oven is empty, the thermostat on high, the door open, and the room properly ventilated. The odor which can be detected at times is due to the evaporation off the substances used to protect the oven and the grill during the period between the time of production and installation of the appliance.

Attention: Only use the bottom shelf of the oven when using the rotisserie to cook (where present). For all other types of cooking, never use the bottom shelf and never place anything on the bottom of the oven when it is in operation because this could damage the enamel. Always place your cookware (dishes, aluminium foil, etc. etc.) on the grate provided with the appliance inserted especially along the oven guides.

Oven and Grill Control Knob (M)

This knob allows you to select the various features of the oven and to set the most appropriate cooking temperature from among those indicated on the knob itself (between **Min** and **Max**).

To light the oven burner, hold a lighted match or lighter near the "F" hole and, at the same time, press down and turn the oven knob counter-clockwise to the **Max** setting.

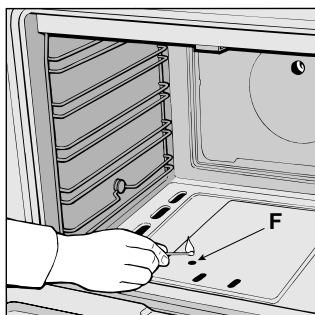

Since the cooker is equipped with a safety device which makes it necessary to keep the knob pressed in for about 6 seconds after the burner has been lighted to allow the gas to pass through freely.

The cooking temperature is selected by matching the desired temperature with the reference mark on the panel; the complete range of temperatures is shown below.

Min	•	150	•	180	•	220	Max
140	145	160	200	250			

The temperature setting is then automatically reached and kept constant by the thermostat (which is controlled by the knob).

To use the grill, turn the knob clockwise till to setting , after holding a lighted match or a lighter close to the grill burner. **In the grill burner equipped with a safety device, the knob must be held pressed in for about 6 seconds in order to activate the flame failure device.** In this way the infrared ray comes on for browning the food or cooking roast, chops, sausages, roast-beef, etc.; for grill cooking, place a drip-pan under the grill to catch the grease.

Important Notice: In the event the flame for the oven accidentally goes out, turn the control knob for the burner to the off position and do not relight the burner for at least one minute.

Important: when using the grill, the oven door must be left partly open by positioning the deflector "D" between door and panel to prevent the cooker knobs from overheating.

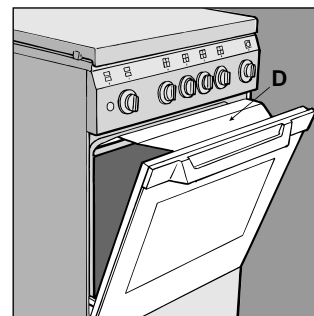

Attention

Avoid the children touch the oven door because it is very hot during the cooking.

WARNING

To remove the sliding protection "A", unscrew screw "S". When you have finished, replace the protection and lock it in place with screw "S".

Before using the oven, make sure the sliding protection "A" is fastened in the correct position.

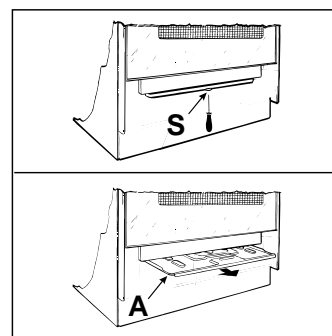

Oven Light Button (O)

This button is marked by the  symbol and switches on the light inside the oven so that you can monitor the cooking process without opening the door.

Cooking Control Timer Knob (only a few models)

Some models are equipped with a timer program to control when the oven shuts off during cooking. To use this feature, you must wind the "P" knob one full turn in the counter-clockwise direction ☺; Then, turn the knob in the clockwise direction ☻, to set the time by matching up the indicator on the control panel with the number of minutes on the knob.

Storage recess below the oven (only a few models)

Below the oven a recess can be used to contain cooking pans and cooker accessories. Moreover, during oven operation, it may be used to keep food warm. To open the storage is necessary turn it downwards.

Caution: this storage recess must not be used to store inflammable materials.

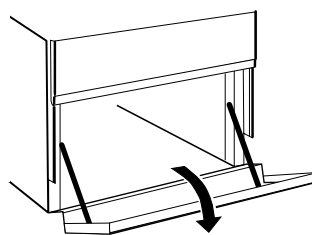

Practical advice for burner use

In order to get the maximum yield it is important to remember the following:

- Use appropriate cookware for each burner (see table) so as to avoid flames overshooting the edges.
- At boiling point turn the knob to minimum.
- Use cookware with lids.
- Always use cookware with flat bottoms.

Burner	∅ Cookware diameter (cm)
Fast (R)	24 - 26
Semi Fast (S)	16 - 20
Auxiliary (A)	10 - 14

Cooking advice

The oven offers a wide range of alternatives which allow you to cook any type of food in the best possible way. With time you will learn to make the best use of this versatile cooking appliance and the following directions are only a guideline which may be varied according to your own personal experience.

Baking cakes

The oven should always be warm before putting in cakes wait till the end of preheating (about 10-15 min.). Cake-baking temperatures are normally around 160°C/200°C. Do not open the oven door during the baking process as this could cause the cake to sink. In general:

Pastry is too dry

Increase the temperature by 10°C and reduce the cooking time.

Pastry dropped

Use less liquid or lower the temperature by 10°C.

Pastry is too dark on top

Place it on a lower rack, lower the temperature, and increase the cooking time.

Cooked well on the inside but sticky on the outside

Use less liquid, lower the temperature, and increase the cooking time.

The pastry sticks to the pan

Grease the pan well and sprinkle it with a dusting of flour or use greaseproof paper.

Cooking fish and meat

When cooking white meat, fowl and fish use low temperatures. (150°C-175°C). When red meat must be superficially well-cooked but succulent inside, it is advisable to start with a high temperature (200-220°C) for a short time, and then to reduce it at a later point. Generally speaking, the more meat there is, the lower the temperature and the longer the cooking time should be. Place the meat in the centre of the grid and put a spill-tray underneath to catch grease drips. Insert the grid so that it is in the middle of the oven. If more heat from below is required, use the 1° bottom shelf.

Cooker routine maintenance and cleaning

Before each operation, disconnect the cooker from the electricity. To assure the long life of the cooker, it must be thoroughly cleaned frequently, keeping in mind that:

- the enamelled parts and the self-cleaning panels are washed with warm water without using any abrasive powders or corrosive substances which could ruin them;
- the inside of the oven should be cleaned fairly often while it is still warm using warm water and detergent, followed by careful rinsing and drying;
- the flame spreaders should be washed frequently with hot water and detergent taking care to eliminate any scale;
- in cookers equipped with automatic lighting, the terminal part of the electronic instant lighting devices should be cleaned frequently and the gas outlet holes of the flame spreaders should be checked to make sure they are free of any obstructions;
- Stainless steel may become marked if it comes into contact with very hard water or harsh detergents (containing phosphorous) for long periods of time. After cleaning, it is advisable to rinse thoroughly and dry. It is also recommended to dry any water drops;
- On models with glass covers, the covers should be cleaned with hot water; the use of rough cloths or abrasives is to be avoided.

N.B: avoid closing the cover while the gas burners are still warm. Remove any liquid from the lid before opening it.

Important: periodically check the wear of the gas hose and substitute it if there are any defects; we recommended changing it every year.

Replacing the oven lamp

- Unplug the oven from the mains;
- Remove the glass cover of the lamp-holder;
- Remove the lamp and replace with a lamp resistant to high temperatures (300°C) with the following characteristics::
 - Voltage 230V
 - Wattage 25W
 - Type E14

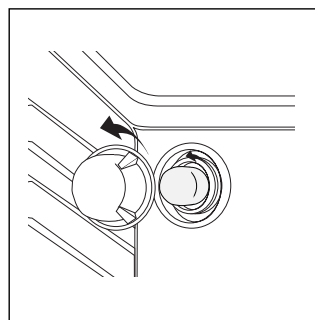

- Replace the glass cover and reconnect the oven to the mains.

Greasing the taps

The taps may jam in time or they may become difficult to turn. If so, they must be cleaned internally and the grease replaced.

N.B: This operation must be carried by a technician authorised by the manufacturer.

Removing the lid

The cooker lid can be removed to facilitate cleaning. To remove the lid, first open it completely and pull it upwards (see figure)

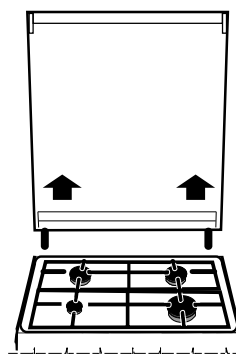

Practical advice for oven cooking

Food to be cooked	Wt. (Kg)	Cooking position of shelves from bottom	Temperature (°C)	Pre-heating time (min)	Cooking time (min.)
Pasta					
Lasagne	2.5	3	210	10	60-75
Cannelloni	2.5	3	200	10	40-50
Pasta bakes au gratin	2.5	3	200	10	40-50
Meat					
Veal	1.7	3	200	10	85-90
Chicken	1.5	3	220	10	90-100
Duck	1.8	3	200	10	100-110
Rabbit	2.0	3	200	10	70-80
Pork	2.1	3	200	10	70-80
Lamb	1.8	3	200	10	90-95
Fish					
Mackerel	1.1	3	180-200	10	35-40
Dentex	1.5	3	180-200	10	40-50
Trout baked in paper	1.0	3	180-200	10	40-45
Pizza					
Napolitan	1.0	3	220	15	15-20
Cake					
Biscuits	0.5	3	180	15	30-35
Tarts	1.1	3	180	15	30-35
Savoury pie	1.0	3	180	15	45-50
Raised Cakes	1.0	3	165	15	35-40
Grill cooking					
Veal steaks	1	4		5	15-20
Cutlets	1,5	4		5	20
Hamburgers	1	3		5	7
Mackerels	1	4		5	15-20
Toast sandwiches	n.° 4	4		5	5

NB: cooking times are approximate and may vary according to personal taste. When cooking using the grill, the dripping-pan must always be placed on the 1st oven rack from the bottom.



Merloni Elettrodomestici

Viale Aristide Merloni 47

60044 Fabriano

Italy

Tel +39 0732 6611

Fax +39 0732 662501

www.merloni.com